

Operator Manual



IMPORTANT - Please make certain that persons who are to use this equipment thoroughly read and understand these instructions and any additional instructions provided prior to operation.

Record the model and serial numbers of your Generator below:

Model No. _____ Serial No. _____

TABLE OF CONTENTS

Safety and operation rules	3
Spark arresting muffler	4
Determining total wattage	5
Operating voltage	5
Installation	6
Before operation	6
Grounding the generator	6
Lubrication	6
Low oil sensor	6
Fuel	6
Cord set wiring	7
DC features	7
Starting the unit	8
Pre-start preparation	8
Starting the engine	8
Applying load	8
Circuit breaker	8
Shutting the generator off	9
Periodic Maintenance	
Maintenance	9
Spark plug	9
Oil type	9
Oil replacement	10
Air filter cleaning	10
Fuel valve filter cleaning	10
Fuel strainer cleaning	10
Exciting the generator	10
Heat shield	10
Engine carburetor icing	
Quick starting tips	10
Service and storage	10
Infrequent service	10
Long term storage	10
Engine troubleshooting	11
Service information	12
Limited warranty	12
Parts drawing/list	13
PM3000	13

SAFETY INFORMATION



DANGER

DANGER indicates a potentially hazardous situation which, if not avoided, WILL result in death or serious injury.



WARNING

WARNING indicates a potentially hazardous situation which, if not avoided, could result in death or serious injury.



CAUTION

CAUTION indicates a potentially hazardous situation which, if not avoided, may result in minor or moderate personal injury, or property damage.

SAFETY AND OPERATION RULES



WARNING - Failure to follow these instructions and warning may result in death, personal injury, or property damage.

1. Read carefully and understand operator manual prior to operation of this product. Follow all warnings and instructions.
2. Know your equipment. Consider the applications, limitations, and the potential hazards specific to your unit.
3. Equipment must be placed on a firm, supporting surface.
4. Load must be kept within rating stated on generator nameplate. Overloading will damage the unit or shorten its life.
5. Engine must not be run at excessive speeds. Operating an engine at excessive speeds increases the hazard of personal injury. Do not tamper with parts which may increase or decrease the governed speed.
6. To prevent accidental starting, always remove the spark plug or cable from the spark plug before maintaining the generator or engine.
7. Units with broken or missing parts, or without protective housing or covers, should never be operated. Contact your service center for replacement parts.
8. Units should not be operated or stored in wet or damp conditions or on highly conductive locations such as metal decking and steel work.
9. Keep the generator clean and free of oil, mud and other foreign matter.
10. Extension cords, power cords, and all electrical equipment must be in good condition. Never operate electrical equipment with damaged or defective cords.
11. Store the generator in a well ventilated area with the fuel tank empty. Fuel should not be stored near the generator.
12. Your generator should never be operated under these conditions:
 - a. Uncontrolled change in engine speed.
 - b. Electrical output loss.
 - c. Overheating in connected equipment.
 - d. Sparking.
 - e. Damaged receptacles.
 - f. Engine misfire.
 - g. Excessive vibration.
 - h. Flame or smoke.
 - i. Enclosed compartment.
 - j. Rain or inclement weather. Do not let the unit get wet when operating.
13. Check the fuel system periodically for leaks or signs of deterioration such as chafed or spongy hose, loose or missing clamps, or damaged tank or cap. All defects should be corrected before operation.
14. The generator should be operated, serviced, and refueled only under the following conditions:
 - a. Start and run the generator outdoors. Do not run the generator in an enclosed





area, even if doors or windows are open; avoid areas where vapors may be trapped, such as pits, garages, cellars, excavations and boat bilges.

DANGER - CARBON MONOXIDE

HAZARD: The engine exhaust contains carbon monoxide, a poisonous, odorless, invisible gas which, if breathed, may cause death or serious personal injury. If you start to feel sick, dizzy or weak while using the generator, shut it off and get to fresh air right away; you may have carbon monoxide poisoning.

- b. Good ventilation for cooling. Air flow and temperatures are important for air cooled units. Temperatures should not exceed 104°ba F ambient (40°ba C).
- c. Refuel the generator in a well lighted area. Avoid fuel spills and never refuel while the generator is running. Allow engine to cool for two minutes prior to refueling.
- d. Do not refuel near open flames, pilot lights, or sparking electrical equipment such as power tools, welders, and grinders.
- e. The muffler and air cleaner must be installed and in good condition at all times as they function as flame arresters if backfiring occurs.
- f. Do not smoke near the generator.

- 15. Ensure that generator is properly grounded. (See "Grounding the generator" section in this manual.)



- 16. Do not wear loose clothing, jewelry, or anything that may be caught in the starter or other rotating parts.
- 17. Unit must reach operating speed before electrical loads are connected. Disconnect loads before turning off engine.
- 18. To prevent surging that may possibly damage equipment, do not allow engine to run out of fuel when electrical loads are applied.

- 19. When powering solid state equipment, a Power Line Conditioner should be used to avoid possible damage to equipment.
- 20. Do not stick anything through ventilating slots, even when the generator is not operating. This can damage the generator or cause personal injury.
- 21. Before transporting the generator in a vehicle, drain all fuel to prevent leakage that may occur.
- 22. Use proper lifting techniques when transporting the generator from site to site. Improper lifting techniques may result in personal injury.

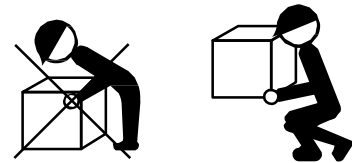

- 23. To avoid burns, do not touch engine muffler or other engine or generator surfaces which became hot during operation.

SPARK ARRESTER

YOUR PRODUCT MAY NOT BE EQUIPPED WITH A SPARK ARRESTING MUFFLER . If

the product will be used around flammable materials, such as agricultural crops, forests, brush, grass, or other similar items, then an approved spark arrester should be installed and is legally required in the State of California. The California statutes requiring a spark arrester are Sections 13005(b), 4442 and 4443. Spark Arresters are also required on some U.S. Forest Service land and may also be legally required under other statutes and ordinances.

DETERMINING TOTAL WATTAGE

In order to prevent overloading and possible damage to your generator it is necessary to know the total wattage of the connected load. To determine which tools and/or appliances your generator will run follow these steps:

1. Determine if you want to run one item or multiple items simultaneously.
2. Check wattage requirements for the items you will be running by referring to the load's nameplate or by calculating it (multiply amps x volts = watts).
3. Total the watts for each item. If the nameplate only gives volts and amps, multiply volts x amps = watts. 1 KW = 1,000 watts.
4. Motorized appliances or tools require more than their rated wattage for start up.

NOTE: Allow 2 1/2 to 4 times the listed wattage for starting equipment powered by electric motors.

5. The generator's rated watts should match or exceed the total number of watts required for the equipment you want to run.
6. Always connect the heaviest load to the generator first, then add other items one at a time.

OPERATING VOLTAGE CAUTION

CAUTION: Operating voltage and frequency requirement of all electronic equipment should be checked prior to plugging them into this generator. Damage may result if the equipment is not designed to operate within a +/- 10% voltage variation, and +/- 3 hz frequency variation from the generator name plate ratings. To avoid damage, always have an additional load plugged into the generator if solid state equipment (such as a television set) is used. A power line conditioner is recommended for some solid state applications.

A power line conditioner should be used when running one or more of the following solid state items:

Garage door openers
Kitchen appliances with digital displays Televisions
Stereos
Personal computers Quartz clocks
Copy machines Telephone equipment

Other solid state equipment may require a power line conditioner. For more information, contact our Customer Service Department at (+63-2) 628 10 50

INSTALLATION WARNING



To avoid possible personal injury or equipment damage, a registered electrician or an authorized service representative should perform installation and all service. Under no circumstances should an unqualified person attempt to wire into a utility circuit.

To avoid backfeeding into utility systems, isolation of the residence electrical system is required.

Before temporary connection of the generator to the residence electrical system, turn off the main service/disconnect.

If your generator is to be used as a stand-by power source in case of utility power failure, it should be installed by a registered electrician and in compliance with all applicable local electrical codes.

Proper use requires that a double throw transfer switch be installed by a licensed qualified electrician so that the building's electrical circuits may be safely switched between utility power and the generator's output, thereby preventing backfeed into the power utility's electrical system.



WARNING



To avoid backfeeding into utility systems, isolation of the residence electrical system is required. Before temporary connection of a generator to the residence electrical

system turn off the main switch. Before making permanent connections, a double throw transfer switch must be installed. To avoid electrocution or property damage, only a trained electrician should connect generator to residence electrical system. California law requires isolation of the residence electrical system before connecting a generator to residence electrical systems. Temporary connection not recommended due to back feeding.

Always follow local codes and regulations that apply to the installation of any item that concerns this product.

1. NFPA 70 - National Electrical Code.
2. NFPA 37 - Standard for Installation and Use of Stationary Combustible Engines.
3. Agricultural Wiring handbook of Farm Standby Electric Power.

BEFORE OPERATION

GROUNDING THE GENERATOR

The National Electric Code requires that this product be properly connected to an appropriate earth ground to help prevent electric shock. A ground terminal connected to the frame of the generator has been provided for this purpose. Connecting a length of heavy gauge (12 AWG min.) copper wire between the generator Ground Terminal and a copper rod driven into the ground should provide a suitable ground connection. However, consult with a local electrician to insure that local codes are being adhered to.

GROUND TERMINAL LOCATION:



GROUND TERMINAL



WARNING



WARNING Do not use a pipe carrying combustible material as the ground source.

LUBRICATION

DO NOT attempt to start this engine without filling the crank case with the proper amount and type of oil. Your generator has been shipped from the factory without oil in the crankcase. Operating the unit without oil can damage the engine.

Fill the engine with oil according to the operator manual. For units with a dipstick, fill oil to the proper level. Units without a dipstick should be filled to the top of the opening of the oil fill.

LOW OIL SENSOR

The unit is equipped with a low oil sensor. If the oil level becomes lower than required, the sensor will activate a warning device or stop the engine.

If generator shuts off and the oil level is within specifications, check to see if generator is sitting at an angle that forces oil to shift. Place on an even surface to correct this.

If engine fails to start, the oil level may not be sufficient to deactivate low oil level switch. Make sure the sump is completely full of oil.

FUEL

Fill the tank with clean, fresh unleaded automotive gasoline. Regular grade gasoline may be used provided a high octane rating is obtained (at least 85 pump octane). We recommend always using a fuel stabilizer. A fuel stabilizer will minimize the formulation of fuel gum deposits during storage. The fuel stabilizer can be added to the gasoline in the fuel tank, or into the gasoline in a storage container.



CAUTION



CAUTION Do not overfill the tank. Keep maximum fuel level 1/4" below the top of the fuel tank. This will allow expansion in hot weather and prevent overflow.

CORD SET WIRING

If your generator is supplied with a 4-wire 120/240V twistlock receptacle ground and neutral may be connected together at the load side.

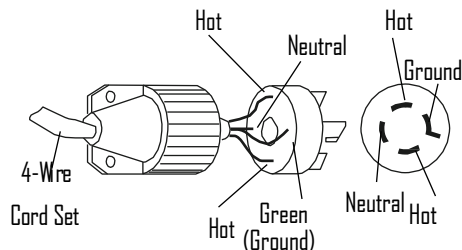

* Neutral - Hot = 120V
Hot - Hot = 240V

DC FEATURES

(Only models equipped with battery chargers)

These generators contain a circuit used for battery charging purposes. A two-prong DC receptacle is provided for this feature.

The battery charger on these generators are referred to as an unregulated taper charger - the most widely used in the market today. The amount of current flowing will depend on the charging voltage and battery's state of charge. As the oncharge output current to the battery decreases, the output current to the battery increases and nearly becomes constant. Taper chargers are intended to be used with the provision that they will be disconnected from the battery after maximum time on charge. Normally a period of 30 to 120 minutes is sufficient to recharge a weak battery.



WARNING



WARNING: Storage batteries give off **EXPLOSIVE** hydrogen gas while charging. Do not allow smoking, open flames, sparks, or spark producing equipment in the area while charging.

Connect the red clip to the positive terminal of the battery. Connect the black clip to the negative terminal of the battery. Insert the DC plug into the DC receptacle to the generator. After the battery is fully charged remove the battery charging cable from the generator and then disconnect from the battery posts.



WARNING



WARNING: Battery electrolyte fluid is compressed of sulfuric acid that can be very dangerous and cause severe burns. Do not allow this fluid to contact eyes, skin, clothing, etc. If contact or spillage does occur, flush the area with water immediately.

DC CIRCUIT BREAKER

The maximum current available from the battery charger circuit is 8.5 amps. An automatic DC circuit breaker has been provided to protect the circuit from overloads and assure that the battery gets recharged. If an overload occurs, the circuit breaker will trip. After it cools, it will automatically reset itself. The battery's maximum rate of charge will eventually reduce to less than 8.5 amps and then to zero as the battery approaches a 100 percent state of charge.



CAUTION

CAUTION: This battery charging system is intended to re-charge weak batteries, not to "boost start" vehicles.

NOTE: When the battery charger circuit is in use, the AC capacity is reduced by 180 watts. Make sure the combined load is within the rated limits.

Before charging a storage battery, check the electrolyte fluid level in all the cells. (Sealed batteries do not require checking). Add distilled water to each cell, if necessary, to bring the level back up to the manufacturer's required level.



STARTING THE UNIT

WARNING



WARNING Gasoline is very dangerous. Serious injury or death may result from fire caused by gasoline contacting hot surfaces.

1. Do not fill fuel tank with engine running.
2. Do not spill fuel while refilling tank.
3. Do not mix oil with gasoline.
4. Follow all instructions and warnings in the operator manual.

PRE-START PREPARATION

Before starting the generator, check for loose or missing parts and for any damage which may have occurred during shipment.



WARNING



This generator must not be operated without all factory installed heat shields in place. Failure to comply may cause the fuel tank to overheat and result in personal injury from fire.

STARTING THE ENGINE

1. Check oil level and fuel.
2. Disconnect all electrical loads from the unit.
3. Open fuel shut off valve.
4. Adjust choke as necessary.
5. Set the engine switch to the "ON" position.
6. Pull on the starter rope with fast steady pull. As the engine warms up, readjust the choke. On electric start models, turn the key switch to "START". Release key switch after the engine starts.



CAUTION



Allow generator to run at no load for five minutes upon each initial start-up to permit engine and generator to stabilize.



DANGER



- Provide adequate ventilation for toxic exhaust gases and cooling air flow.
- Do not start or run the generator in an enclosed area, even if door or windows are open.
- Engines give off carbon monoxide, an odorless, colorless, poison gas.
- Breathing carbon monoxide can cause nausea, fainting or death.

APPLYING LOAD

This unit has been pretested and adjusted to handle its full capacity. When starting the generator, disconnect all load. Apply load only after generator is running. Voltage is regulated via the engine speed adjusted at the factory for correct output. Readjusting will void warranty.



CAUTION



When applying a load, do not exceed the maximum wattage rating of the generator when using one or more receptacles. Also, do not exceed the amperage rating of any one receptacle.

CIRCUIT BREAKER



CAUTION



Do not apply heavy electrical load during break-in period (the first two to three hours of operations).

The receptacles are protected by an AC circuit breaker. If the generator is overloaded or an external short circuit occurs, the circuit breaker will trip. If this occurs, disconnect all electrical loads and try to determine the cause of the problem before attempting to use the generator again. If overloading causes the circuit breaker to trip, reduce the load. NOTE: Continuous tripping of the circuit breaker may cause damage to generator or equipment. The circuit breaker may be reset by switching to the ON position.

SHUTTING THE GENERATOR OFF

1. Remove entire electrical load.
2. Let the engine run for two minutes without load.
3. Move the engine switch to the "OFF" position. (Turn the key switch to "OFF" on the electric start models).
4. Do not leave the generator until it has completely stopped.
5. Close the fuel shut off valve if the engine is to be put in storage or transported.
6. If a cover is used, do not install until unit has cooled.

PERIODIC MAINTENANCE

ITEM	NOTES	Daily (Before operation)	Initial 20 hours	Every 50 hours	Every 100 hours
Spark Plug	Check condition. Adjust gap and clean. Replace if necessary.			●	
Engine Oil	Check oil level.	●			
	Replace.		●		●
Air Filter	Clean, replace if necessary.			●	
Fuel Filter	Clean fuel filter and fuel tank strainer. Replace if necessary.				●
Fuel Line	Check fuel hose for cracks or other damage. Replace if necessary.	●			
Exhaust System	Check for leakage. Retighten or replace gasket if necessary.	●			
	Check muffler screen. Clean/ replace if necessary.				●
Carburetor	Check choke operation.	●			
Starting System	Check recoil starter operation.	●			
Fittings/ Fasteners	Check. Replace if necessary.				●

MAINTENANCE

SPARK PLUG

Remove the spark plug and clean the electrodes section with a wire brush or sandpaper. Next, set the gap at .028/.031 inches (0.7-0.8 mm) by adjusting the negative electrode. Replace the spark plug with correct torque: 14 ft-lb (20 N.m)



CAUTION

Replace with only the same type of spark plug which was removed. An improper spark plug can cause the engine to overheat, emit smoke, or otherwise perform poorly.

OIL TYPE

Use new good quality oil, SE, SF, or SD grade. The oil to be used depends upon the temperature at which the engine is operated:

Below 32°b0 F (0°b0 C) - SAE 10W, 10W-30, or 10W-40

32 to 80°b0 F (0 to 25°b0 C) - SAE 20W, 10W-30, or 10W-40

80 to 95°b0 F (25 to 35°b0 C) - SAE 30W, 10W-30, or 10W-40 Above 95°b0 F (35°b0 C) - SAE 40W

OIL REPLACEMENT

1. Change oil while engine is warm.
2. Place the generator unit on a level surface.
3. Remove the oil filler cap.
4. Open the oil drain plug and let oil drain completely into a pan placed under the engine.
5. Check gaskets. Replace if required.
6. Reinstall the oil drain plug and refill engine with clean oil.
7. Replace the oil filler cap.

AIR FILTER CLEANING

1. Unscrew the air filter cover.
2. Remove filter element and wash well in solvent.
3. Pour a small amount of oil onto the filter element and gently squeeze out any excess oil.
4. Replace the filter element and air filter cover.
5. Be sure the filter cover seals properly all around.

FUEL VALVE FILTER CLEANING

1. Remove the cup at the bottom of the fuel valve with a small wrench.
2. Remove the fuel valve filter.
3. Clean and wash out the filter and cup and replace.

FUEL STRAINER CLEANING

1. Remove the plastic fuel strainer, located below the fuel tank cap.
2. Wash the strainer in solvent and replace.

EXCITING THE GENERATOR:

If there is a loss of residual magnetism (voltage will not build up), it may be necessary to re-excite the unit.

NOTE: Your generator is a brushless unit. Please contact your local service center or the Powertech Asia Pacific Inc., Service Department for assistance with exciting your generator.

HEAT SHIELD:

Inspect to ensure that all heat shields and heat deflectors are intact and in place. Do not remove any parts or modify parts. Removing or modifying parts could cause serious damage to the unit.

ENGINE: Carburetor Icing

During the winter months, rare atmospheric conditions may develop which will cause an icing condition in the carburetor. If this develops, the engine may run rough, loose power, and may stall. Call Product Service for more information.

QUICK STARTING TIPS FOR UNITS THAT HAVE BEEN SITTING FOR AWHILE:

If your unit has been sitting around for a long time period and is hard to start, try doing some of these easy steps before calling the Customer Hotline.

1. Check the oil level.
2. Replace the old fuel.
3. Change the spark plug.
4. Check the fuel lines. Make sure the fuel valve is open.
5. Check all generator parts for integrity.
6. Clean the Carburetor.

SERVICE AND STORAGE

INFREQUENT SERVICE

If the unit is used infrequently, difficult starting may result. To eliminate hard starting, run the generator at least 30 minutes every month. Also, if the unit will not be used for some time, it is a good idea to drain the fuel from the carburetor and gas tank.

LONG TERM STORAGE

When the generator set is not being operated or is being stored more than one month, follow these instructions:

1. Replenish engine oil to upper level.
2. Drain gasoline from fuel tank, fuel line and carburetor.
3. Pour about one teaspoon of engine oil through the spark plug hole, pull the recoil starter several times and replace the plug. Then pull the starter until you feel the piston is on its compression stroke and leave it in that position. This closes both the intake and exhaust valves to prevent the inside of the cylinder from rusting.
4. Cover the unit and store in a clean, dry place that is well ventilated away from open flame or sparks.

NOTE: We recommend always using a fuel stabilizer. A fuel stabilizer will minimize the formulation of fuel gum deposits during storage. The fuel stabilizer can be added to the gasoline in the fuel tank, or into the gasoline in a storage container.

ENGINE TROUBLESHOOTING

CONDITION

PROBABLE CAUSE

CORRECTIVE ACTION

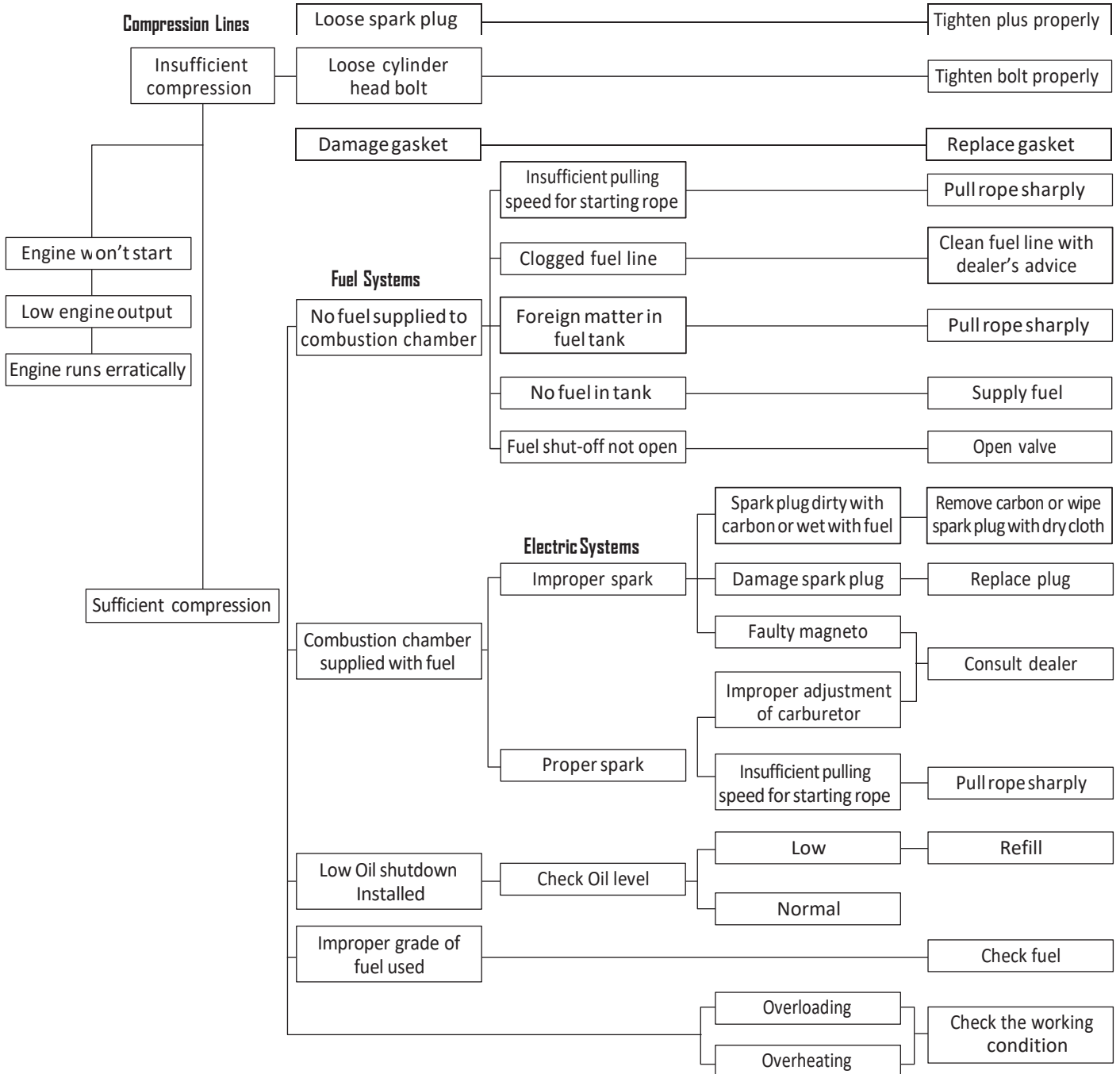

SERVICE INFORMATION

CONTACT POWERTECH ASIA PACIFIC INC. PRODUCT SERVICE DEPARTMENT AT (+63-2) 628-1050

HOW TO ORDER REPLACEMENT PARTS

Even quality built equipment such as the electric generator you have purchased, might need occasional replacement parts to maintain it in good condition over the years. To order replacement parts, please give the following information:

1. Model No. and Serial No. and all specifications shown on the Model No./Serial No. plate.
2. Part number or numbers as shown in the Parts List section.
3. A brief description of the trouble with the generator.

LIMITED WARRANTY

Warranty Coverage: Powertech Asia Pacific Inc., (the Company) warrants to the original retail customer that it will repair or replace, free of charge, any parts found by the Company or its authorized service representative to be defective in material or workmanship. This warranty covers the cost of replacement parts and labor for defects in material or workmanship.

Not Covered:

- Transportation charges for sending the product to the Company or its authorized service representative for warranty service, or for shipping repaired or replacement products back to the customer; these charges must be borne by the customer.
- If a separate operator's manual and engine warranty from the engine manufacturer is included with this product, only that warranty will apply to the engine.
- Damages caused by abuse or accident, and the effects of corrosion, erosion and normal wear and tear.
- Warranty is voided if the customer fails to install, maintain and operate the product in accordance with the instructions and recommendations of the Company set forth in the owner's manual, or if the product is used as rental equipment.

- The Company will not pay for repairs or adjustments to the product, or for any costs or labor, performed without the Company's prior authorization.
- Consumable parts such as battery, spark plug and air cleaner.

Warranty Period: One (1) year from the date of purchase on products used solely for consumer applications; if a product is used for business or commercial applications, the warranty period will be limited to ninety (90) days from the date of purchase. For warranty service, the customer must provide dated proof of purchase and must notify the Company within the warranty period.

Call: (+63-2) 628-1050

EXCLUSIONS AND LIMITATIONS: THE COMPANY MAKES NO OTHER WARRANTY OF ANY KIND, EXPRESS OR IMPLIED. IMPLIED WARRANTIES, INCLUDING WARRANTIES OF MERCHANTABILITY AND OF FITNESS FOR A PARTICULAR PURPOSE, ARE HEREBY DISCLAIMED. THE WARRANTY SERVICE DESCRIBED ABOVE IS THE EXCLUSIVE REMEDY UNDER THIS WARRANTY; LIABILITY FOR INCIDENTAL AND CONSEQUENTIAL DAMAGES IS EXCLUDED TO THE EXTENT PERMITTED BY LAW.

This warranty gives you specific legal rights, and you may also have other rights which vary from state to state. Some states do not allow a disclaimer of implied warranties, or the exclusion or limitation of incidental and consequential damages, so the above disclaimers and exclusions may not apply to you.

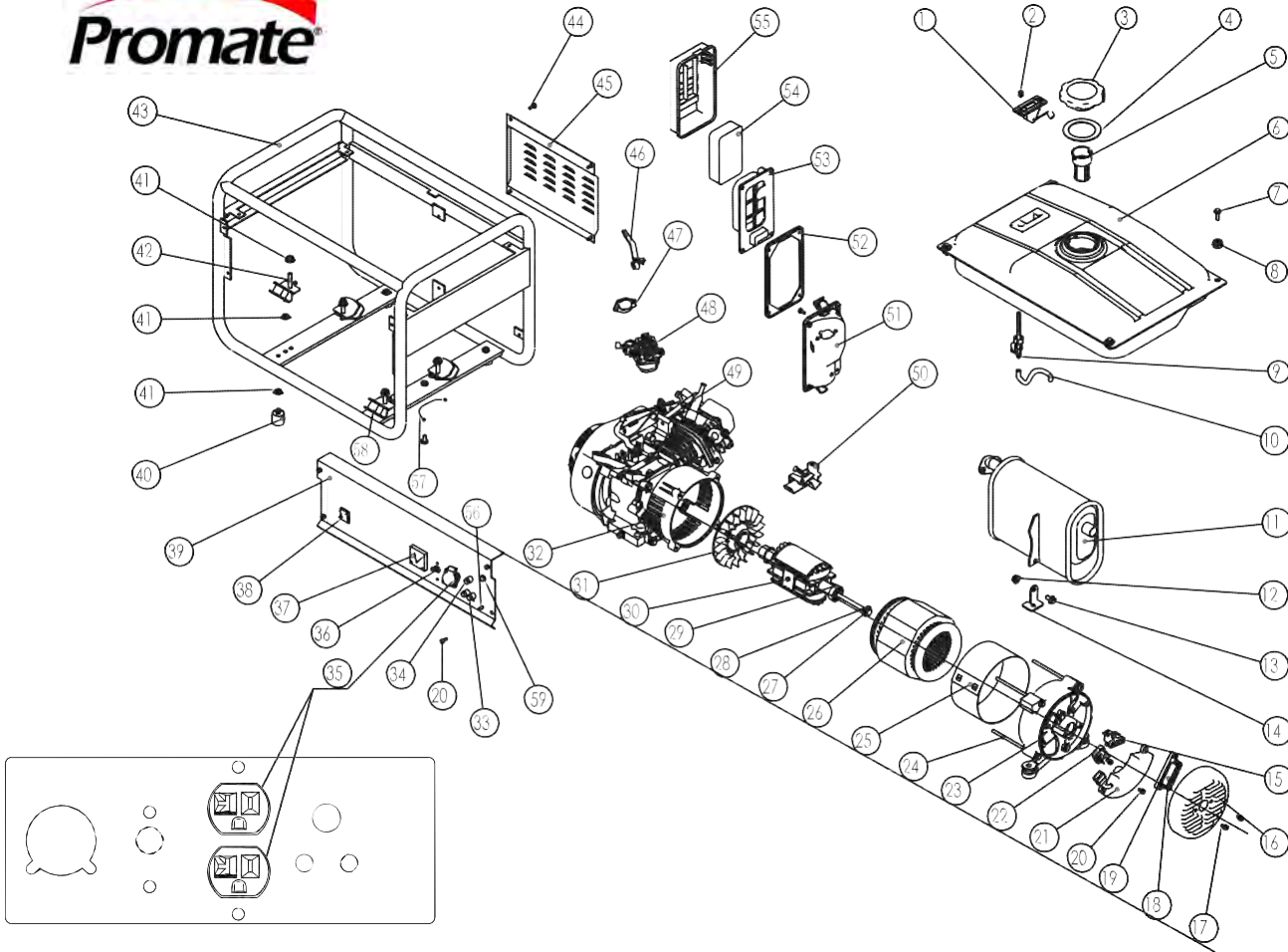

GASOLINE GENERATOR PARTS LIST

Ref.No	Part No.	Description	Qty.	Note
1	SF168FD-1160100	Fuel meter	1	
2	GB819-85	Screw M5X6	2	
3	SF168FD-1160200	Fuel tank cap	1	
4	SF168FD-1160200	Fuel tank cap seal	1	
5	SF168FD-1160500	Fuel filler	1	
6	SF168FD-1160001A	Fuel tank	1	
7	GB5789-86	Screw M6X16	4	
8	SF168FD-1163000	Vibration absorber	4	
9	SF168FD-1160400	Fuel cock	1	
10	SF168FD-1160002A	Fuel hose	1	
11	SF168FD-1100200	Muffler	1	
12	GB6177-86	Nut M6	1	
13	GB5789-86	Screw M6X16	1	
14	SF168FD-1100002B	Muffler rack	1	
15	SF02FD-1152035	Alternator brush	1	
16	SF02FD-1152002	Rear cover	1	
17	GB5789-86	Screw M5X10	2	
18	GB5781-87	Screw M5x16	2	
19	SF168FD-1150230	Terminal	1	
20	GB5781-86	Screw M5x15	2	
21	SF02FD-1152031	AVR	1	
22	SF168FD-1152004	Bridge rectifier	1	
23	SF02FD-1152032	Alternator rear frame	1	
24	GB5789-86	Screw M6x155	4	
25	SF025FD-1152001	Stator protector	1	
26	SF025FD-1152020	Stator	1	
27	GB5780-86	Screw M8x227	1	
28	GB90-85	Flat washer	1	
29	GB279-88 6202	Ball bearing	1	
30	SF025FD-1152010	Rotor	1	
31	SF02FD-1152009	Cooling fan	1	
32	SF168FD-2-1030007	Crankcase cover	1	
33	SF168FD-1710004	+,- pole	2	
34	SF02FD-1151202A	Fuse	1	
35	SF02FD-1151203A	Duplex Receptacle	1	
36	SF02FD-1151202	AC Circuit breaker	1	
37	SF02FD-1151204A	Volt meter	1	
38	SF02FD-1151205A	Switch	1	
39	SF02FD-1151200A	Control panel	1	
40	SF02FD-1151400	Rubber absorber	4	

Ref.No	Part No.	Description	Qty.	Note
41	GB6170-86	Nut M8	12	
42	SF02FD-1151300	Vibration rubber II	2	
43	SF025FD-1151100A	Steel frame assembly	1	
44	GB5789-86	Screw M6x12	4	
45	SF02FD-1151002	Muffler protector	1	
46	SF02FD-1151201A	Choke lever	1	
47	SF168FD-1130005	Air cleaner gasket	1	
48	SF168FD-1130003	Carburetor	1	
49	SF168F-2-1000000	Engine	1	
50	SF168FD-1111100	Throttle control rack	1	
51	SF168FD-1090100	Air cleaner rear seat	1	
52	SF168FD-1090002	Air cleaner seal	1	
53	SF168FD-1090003	Air cleaner element rack	1	
54	SF168FD-1090004	Air cleaner element	1	
55	SF168FD-1090200	Air cleaner cover	1	
56	SF02FD-1151208-M	Grounding bolt	1	
57	SF02FD-1151207-M	Grounding wire	1	
58	SF02FD-1151300A	Vibration absorber I	2	
59	SF02FD-1151201A	Indicative lamp	1	

• Spare parts of engine, please make references to SPE200, excluding air cleaner, muffler and tank.
 • Please provide following information for ordering parts and maintenance:

• Model number
 • Part description, reference and part number as shown in parts list

